

# AMIAD Automatic Filters

## "MEGA-EBS" FILTER

Serial Number: \_\_\_\_\_

Order Number: \_\_\_\_\_

Catalogue Number: \_\_\_\_\_

Filtration Degree: \_\_\_\_\_

Tested By: \_\_\_\_\_

### Installation, Operation and Maintenance Instructions

Ref. 06.2000

# TABLE OF CONTENTS

Technical specifications .....	3
Safety instructions .....	4
Dimensional and recommended installation drawing.....	5
Description and filter operation .....	6
Installation .....	7-8
Maintenance.....	9
Parts schedule.....	10
Parts drawing General view.....	11
Parts drawing - Section 1 .....	12
Parts drawing - Section 2 .....	13
Parts drawing Section 3 .....	14
Parts drawing Section 4 .....	15

With any inquiry please quote Filter Serial Number, located on the filter housing.

# TECHNICAL SPECIFICATIONS

## General

Maximum flow rate	4,000 m <sup>3</sup> /h	17,600 USgpm	Consult manufacturer for optimum flow depending on filtration degree & water quality.
Min. working pressure	2.5 bar	35 psi	or lower if pressure is increased for flushing.
Max. working pressure	10 bar	150 psi	16 bar = 240 psi upon request.
Filter area	40,000 cm <sup>2</sup>	6200 in <sup>2</sup>	
Inlet/Outlet diameter	400- 600 mm	16 24 INCH	Flange standards as per request.
Filter housing	1,400 mm	55"	Epoxy-coated steel, or other on request.
Max. working temperature	80°C	176°F	
Weight	2,250 kg. (empty)	4,960 lb. (empty)	
	3,900 kg. (with water)	8,600 lb. (with water)	

## Flushing data

Exhaust valve	4 X 80 mm	4 X 3"	
Flushing cycle time	140 - 50 seconds	140 - 50 seconds	
Wasted water per cycle	2,000 liter	530 gallon	at 2 bar = 30 psi
Minimum flow for flushing	50 - 200 m <sup>3</sup> /h	220 - 880 USgpm	at 2 bar = 30 psi

## Control and electricity

Control voltage	24V AC	(12V or 24V DC upon request)
Electric motor	4 X 1/2 HP	50 / 60 Hz, 18 / 22 Gear output R.P.M.
Rated operation Voltage	3 phase	220 / 380 / 440 V, 50 / 60 Hz
	Single phase	110 / 220 V, 50 / 60 Hz
Current consumption	1.5 Amp.	(With 3 phase 380 / 440 V)

## Construction materials

Filter Housing and Lid	Epoxy-coated carbon steel 37-2
Screens	Stainless Steel 316
Cleaning mechanism	Stainless Steel 316, POM
Exhaust valve	Epoxy-coated cast iron, Natural Rubber
Seals	Synthetic Rubber, Teflon
Control	Aluminum, Brass, Stainless Steel, PVC

## Standard filtration degrees

	Stainless Steel Weavewire Screen									
Micron	800	500	300	200	130	100	80	50	25	10
Mm	0.8	0.5	0.3	0.2	0.13	0.1	0.08	0.05	0.02	0.01
Mesh	20	30	50	75	120	155	200	300	450	600

# SAFETY INSTRUCTIONS

## General

1. Prior to installation or any treatment given to the filter, read carefully the installation and operation instructions.
2. While treating the filter all conventional safety instructions should be observed in order to avoid danger to the workers, the public or to property in the vicinity.
3. Please note, the filters enters into a flushing mode automatically, without prior warning.
4. No changes or modification to the equipment are permitted without a written notification given by the manufacturer or by its representative, on the manufacturer behalf.

## Installation

1. Install the filter according to the installation instructions detailed in this manual.
2. Make sure to leave enough clearance so as to enable easy access for future treatments and safe maintenance operations.
3. Electric wiring should be performed by an authorized electrician only, using standardized and approved components.
4. Install main power disconnect cut-off switch close to the control panel.
5. If the control panel is installed far away and there is no eye contact with the filter, a power disconnect cut-off switch should be installed near each filter unit.
6. Installation of the filter should be performed so as to avoid direct water splashing on the electrical components or on the control panel.
7. Extra safety devices should be installed on hot water applications to avoid skin burn danger.

## Operation, Control and Maintenance

1. Disconnect the filter from power supply before maintenance or treatment.
2. Loosening or unscrewing bolts should be done only after the pressure in the filter had been released.
3. Avoid splashing and water leaking so as to minimize slipping electrifying danger or damage to the equipment caused by moisture.
4. Always open and close valves slowly and gradually.
5. Remove grease and fat material residues in order to avoid slipping.
6. After treatment has been completed, re-assemble the protection covers of the drive mechanism.
7. Manual cleaning of filter element using high water pressure or steam, should be performed in accordance with the cleaning system instructions and without endangering the operator or his vicinity.
8. Manual cleaning of filter element using acid or other chemical agents, should be performed in accordance with the relevant material safety instructions and without endangering the operator or his vicinity.

## Use of Lifting Equipment

1. While using lifting equipment, make sure that the filter or the lifted part is chained securely and in a safe manner.
2. Do not leave lifted equipment if there is no necessity. Avoid working below lifted equipment.
3. Wear a safety helmet while using lifting equipment.

# DIMENSIONAL DRAWING AND RECOMMENDED INSTALLATION

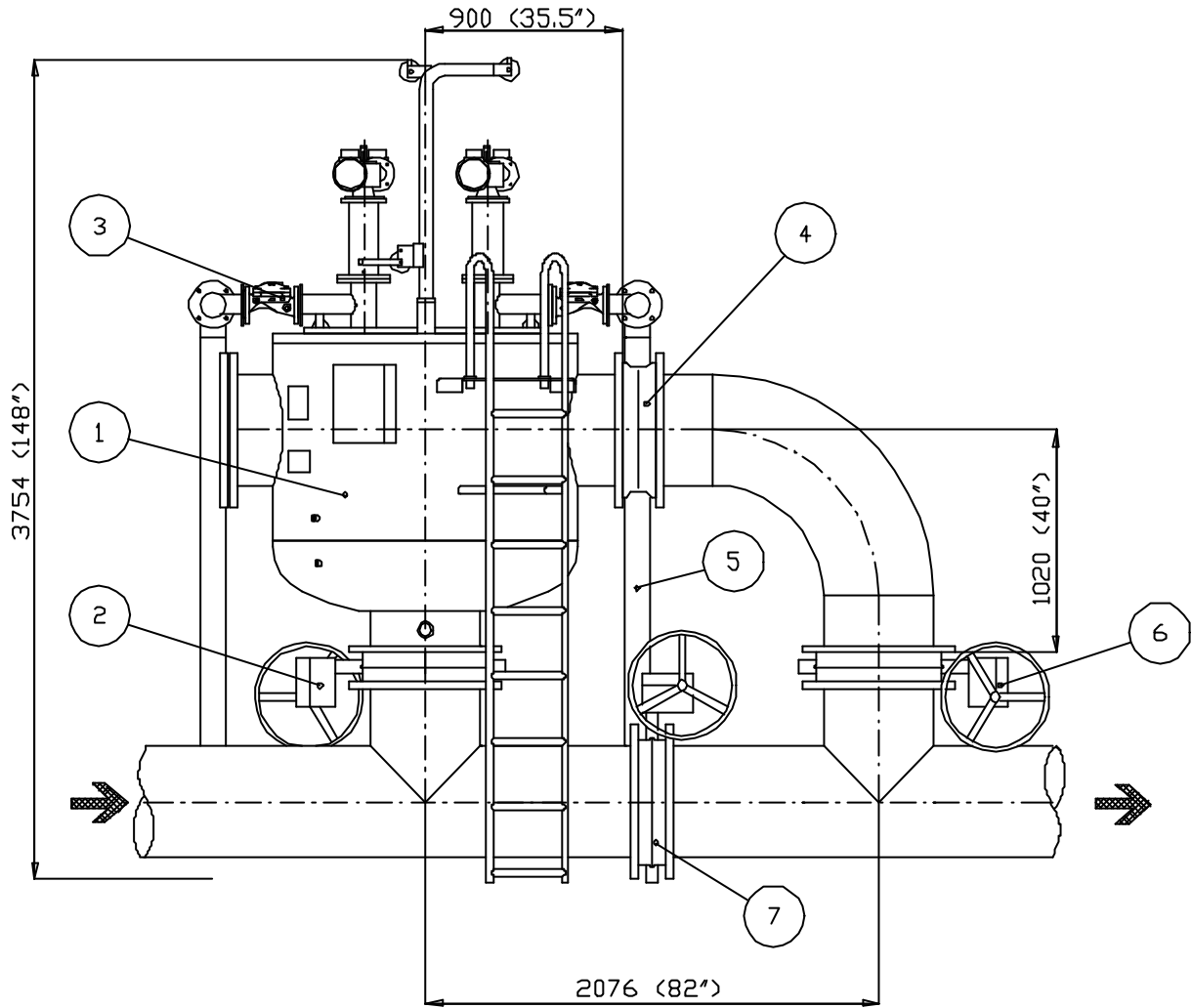

## Key:

Dimensions in mm (inches).

1. 20" MEGA EBS filter
2. 20" Inlet Valve
3. 3" exhaust Valve
4. 20" Non Return Valve
5. 4" Flushing Pipe
6. 20" Outlet Valve
7. 20" By-Pass Valve

# DESCRIPTION OF FILTER OPERATION

## Filtering process:

The MEGA EBS is a sophisticated yet easy-to-operate automatic filter, with a self-cleaning mechanism driven by electric motors. The MEGA EBS consists of four filter unit and is designed to work with various types of screens in filtration degrees from 800 to 10 micron, and is available in 16", 18", 20" and 24" inlet/outlet diameter.

The water enters through the inlet pipe into the fine screens from inside out. The "filtration cake" accumulates on the fine screen surface and causes head loss to develop.

## Self-cleaning process:

The MEGA EBS will start the self-cleaning process when the pressure differential across the screens reaches a pre-set value or a predetermined lapse of time.

Cleaning of a filter element is carried out by a suction scanner, which rotates in a spiral movement while removing the filtration cake from the screen and expels it out through the exhaust valve.

The scanner rotation is operated by a 2-way (fwd/rev) drive unit, which is attached to the scanner by a threaded shaft, providing the linear movement.

The exhaust valves are activated for the duration of the cleaning cycle by a 3-way solenoid. During the self-cleaning process, which takes approximately 35 seconds for each filter element, filtered water continues to flow downstream of the filter.

## Different modes of filtration:

The filtration system may be found in one of the following modes:

1. Filtering mode: This is the normal function condition. Flushing will not occur & the power light on the control board is lit.
2. Flushing mode: A mode in which the flushing process is in progress. The motors and the exhaust valves are operating according to the program.
3. Continuous flushing mode: It is possible to activate the self-cleaning mechanism continuously by changing the switch near the timer in the control board to "CONT." position.
4. Malfunction mode: During malfunction mode the self-cleaning operation is stopped, the malfunction light on the control board is turned on and an external output is activated with 24V AC.

The filtration system may enter a malfunction mode in the following cases:

- 1st. When there is a continuous signal from the pressure differential switch for a duration of more than 20 minutes. This means that the self-cleaning process is not successful.
- 2nd. When one of the motor protectors is activated, manually or due to overload (the other elements will continue to operate).
- 3rd. As a result of a malfunction in one of the limit switches (the other elements will continue to operate).

## Initiation of self-cleaning:

The filter will enter the self-cleaning process as a result of any of the following causes:

1. A signal from the Pressure Differential Switch (PDS) - The PDS which is situated on the filter body, sends an electric signal when the pressure differential across the screen reaches the pre-set value (usually 0.5 bar =7 psi). The control board registers the signal and operates the flushing process according to its program.
2. Manually pressing the "TEST" push button at the control board.
3. The TIMER installed in the control board allows operation of self-cleaning process at time intervals that can be set up, independent from the head loss factor. The timer resets after every flushing cycle.
4. A signal from Continual flushing switch - This switch in the control board allows operation in continuous flushing mode; meaning, the filter is flushing itself all the time regardless of flow rate or water quality.

## Cleaning cycle stages of a single filtration unit:

- 1) The exhaust valve opens to atmosphere.
- 2) Five seconds delay.
- 3) The motor starts rotating the suction scanner shaft until it reaches the top limit switch.
- 4) Suction scanner stops and the exhaust valve closes.
- 5) Two seconds delay.
- 6) The motor starts rotating the suction scanner shaft backward, until it reaches the bottom limit switch.
- 7) Suction scanner stops.
- 8) The filter is ready for the next flushing cycle.

## Cleaning cycle of the MEGA EBS unit:

The four filter units are flushing in sequence; one unit at a time, or two units at a time or all four units simultaneously.

A common PD Switch provides the signal for flushing of the entire system.

- 1) Unit #1 flushes as described above.
- 2) The exhaust valve of unit #2 opens as soon as the suction scanner of unit #1 reaches its top limit switch.
- 3) The cycle ends when the suction scanner of unit #4 has reached its top limit switch.

# INSTALLATION

## Design recommendations

1. If flow increases and pressure drops dramatically for a long period of time during network filling-up, it is recommended that a pressure sustaining valve is installed downstream of the filter. The pressure-sustaining valve will ensure a controlled filling-up of the line.
2. If continual water flow is essential even during maintenance period, it is recommended that a manual or automatic by-pass is installed, and the isolating valves will be used to isolate the filter unit.
3. In places where there is an expected temporary worsening of water quality, it is possible to operate an emergency-flushing program. In order to do so, a hydraulic controlled valve has to be installed downstream of the filter. For details, please consult the manufacturer.

## Installation instructions

1. Select a convenient location for the installation of the filter where operation and maintenance will be optimal. It is recommended that a lifting auxiliary is available for maintenance.
2. Install the filter vertically. Please note that a minimum clearance of 300 mm (12 In.) (not including a crane) is required in order to allow disassembly of the unit.
3. Ensure the direction of flow according to the arrows marked on the filter housing. (Flow outlet will always be from the side; flow inlet is from the bottom).
4. Installation of a mechanical non-return valve downstream of the filter is required.
5. If possible, prior to installing the filter, flush the main line, at the connection point thoroughly, in order to remove large objects which may damage the filters internal mechanism.
6. Install a drainage pipe to the exhaust manifolds. Minimum 4" diameter for a maximum pipe length of 20 meters (60 feet), for longer drainage, 6" pipe diameter must be used for a maximum length of 40 meters (120 feet). Please note that no restriction is allowed on the drainage pipe. For special applications, please consult the manufacturer.
7. If the system is designed to operate with working pressure higher than 6 bar (85 psi), it is recommended that a manual valve is installed on the exhaust pipe, in order to enable regulation of the flushing flow rate.
8. The user should arrange suitable lighting at the area of the filter to enable good visibility and safe maintenance.
9. The user should arrange suitable platforms and safety barriers to enable easy access to the filter without climbing on pipes and other equipment.

## IMPORTANT !!

- **Prevent static back pressure or reverse flow through the filter.**
- **Install a non-return valve at the outlet of the filter.**
- **Install a manual or a hydraulic valve downstream of the filter.**

## Electric wiring

1. Install the control board in a dry and protected place (It is possible to order a special control board for out-door installation).
2. Power connection to the control board:
  - a. Connect a three-phase voltage source through a semi-automatic switch, or 16 Amp. fuse to the L1 L2 L3 inlet at the terminal strip in the control board.
  - b. Earth the control board.
3. Power connection to the motors:

Connect the drive unit to the control panel by means of a 4 x 2.5-mm (12 or 14 AWG) wire in flex-conduct. Use a long enough cable to allow removal of the drive unit and placing it near the filter for maintenance, without having to disconnect it from the cable. (It is recommended that this installation meets or exceeds local or national electrical codes, this is a "high" voltage connection).
4. Control wiring:

Connect between the control terminal box on the filter and the control board by means of 6 x 1.5 mm<sup>2</sup> (16 AWG) wires in flex-conduct. The numbers on the terminals in the board and in the junction box are identical.

## Startup Procedure

- 1) Check and verify that wiring between the filter and the control board is done according to the provided wiring instructions.
- 2) Switch "OFF" motor protectors E1 - E4
- 3) Switch "ON" all circuit breakers.
- 4) Set selector ITSW to the off position (PD only).
- 5) Switch on E1 and watch the rotation direction of the motor of filter unit #1. If the motor rotates counterclockwise i.e. the suction scanner moves upward, stop it immediately by turning E1 to the off position. Change the motor direction by switching between two phases.  
If the motor rotates clockwise i.e. the suction scanner moves downward, let it continue until it reaches the lower limit switch and stops.
- 6) Repeat the above with filter elements #2, 3 and 4.
- 7) Press the "GROUP TEST" push button and verify that the filters are functioning according to the sequence described in this document.
- 8) Open the water supply and pressurize the filter. It is highly recommended that first "wet" operation is done with static pressure and no flow i.e. the outlet valve is open and the by-pass of the system is open.
- 9) Turn SDSW selector to "Double" and operate a flushing cycle by pressing the group test push-button. Verify that everything is working properly as described above.
- 10) Operate and simulate the different events by closing the 1/4" Manometer Valves of the PD switches for 5 seconds.
- 11) If everything is functioning as described, open the outlet valves of the filter and gradually, close the by-pass valve.
- 12) Set IT to 4 - 8 hours and turn selector ITSW to the on position (PD & Time). Follow and monitor the functioning of the filtration system, change IT setting if required.

# MAINTENANCE

## General inspection

In order to check the proper operation of the filter, close the low pressure 1/4" valve to the pressure differential switch for a period of 5 seconds. This will initiate the self-cleaning cycle: Check that the exhaust valves opens, that the scanner moves upwards, and when it reaches the top limit switch - verify that the exhaust valves closes.

## Weekly maintenance

1. Check that the filter operates properly, following a general inspection.
2. Clean the 3/4" filter (close the 3/4" valve and operate a flushing cycle in order to release pressure and then open the bowl).
3. Check that there is grease on the drive shaft, and drive bushing. Add grease if necessary.
4. Take care of any leakage from the scanner shaft. If necessary, replace the Sealing flange Internal O-Ring (24.1)

## Changing the sealing flange internal O-ring:

1. Close the inlet valve to the filter and release the pressure.
2. Verify that if the Suction Scanner is in the lower position.
3. Remove the Split pin (20.2) and pull out the connecting pin (20.1).
4. Operate a flushing cycle.
5. Stop the motor operation when the drive shaft reaches half way of its movement. The drive shaft is now separated from the Suction Scanner.
6. Unscrew nuts (27) and pull the sealing flange (26).
7. Remove the used internal o-ring and clean the o-ring seat.
8. Insert a new o-ring (24.1)
9. Apply some grease on the external o-ring and on the shaft.
10. Tighten the sealing flange nuts (27).
11. Re-connect the drive shaft to the suction scanner shaft.
12. Operate the control board and open the filter inlet valve.

## Maintenance prior to long term cessation of filter op.

The following must be done if the filter will not operate for more than a month.

1. Operate flushing cycle (If possible, with a closed downstream valve).
2. Disconnect the control board from the power before the limit switch disc reaches the switch.
3. Release pressure from the filter.
4. Grease the drive shaft and the drive bushing.
5. Clean the 3/4" control filter.

## Maintenance prior to re-operation

1. Connect the control board to the mains.
2. Check proper operation of the filter.
3. Grease the drive shaft and the drive bushing.
4. If necessary change the Sealing flange Internal O-Ring.

## **IMPORTANT !!**

**THE DRIVE SHAFT MUST BE LUBRICATED WITH HEAVY-DUTY, WATER RESISTANT GREASE, THAT WILL NOT OXIDIZE. (SHELL, DARINA EP-2 OR SIMILAR).**

# PARTS SCHEDULE

Refer to drawing on pages 12 - 15

No.	Description
1	Filter housing
2	Lid Seal
3	Lower Screen Support
3.1	Lower Bearing
3.2	Lower Bearing O-Ring
4	Cylinder seal
5	Filter cylinder
6	Cylinder seal
7	Suction scanner
7.1	Scanner shaft
7.2	Slotted Spring Pin 10 X 60
7.3	scanner nozzle (x 6)
8	Upper bearing
8.1	Upper Bearing External O-Ring
8.2	Upper Bearing Internal O-Ring
10	Filter lid
11	Bolt M20x100 (Plus washers and nuts)
12	Exhaust valve seal
13	Solenoid valve
14	3" Exhaust valve
14.1	Bolt M16x75 (Plus washers and nuts)
16	Ball valve 3/4"
17	3/4" Control Filter 0.2 mm
18	Adjustable P.D switch
19	Electrical junction box
20	Threaded drive shaft
20.1	Connecting pin
20.2	Split pin
20.3	Drive shaft key
21	Drive Shaft housing seal

No.	Description
22	Drive Shaft housing
22.1	Drive Shaft housing cover
23	Bolt M16 x 60 (Plus washers and nuts)
24	External Sealing Flange O-Ring
24.1	Internal Sealing Flange O-Ring
25	Socket set screw M10 x 50 (x2)
26	Sealing flange
27	Nut M10 (x2)
27.1	Washer M10
28	Limit switch plate
28.1	Socket Set Screw M4 x 15 (x2)
29	Lower limit switch (NC)
29.1	Upper limit switch (NC)
29.2	Bolt M6 x 20 (x 2)
29.3	Limit switch sling
29.4	Nut M6 (x 2 )
29.5	Spring washer M6 (x 2)
29.6	Washer M6 (x 2)
29.7	Washer M6 (x 2)
29.8	Bolt M4 x 25 (x 4)
29.9	Washer M4 (x 4)
29.10	St.St. Locknut M4 (x 4)
31	Drive bushing
32	Bolt M6 x 35 (x 3)
32.1	St.St. Locknut M6 (x 3)
32.2	Washer M6 (x 3)
32.3	Washer M6 (x 3)
33	Bolt M10 x 40 (Plus washers and nuts)
34	Drive unit assembly
35	Drive Shaft Cover

# PARTS DRAWING General view

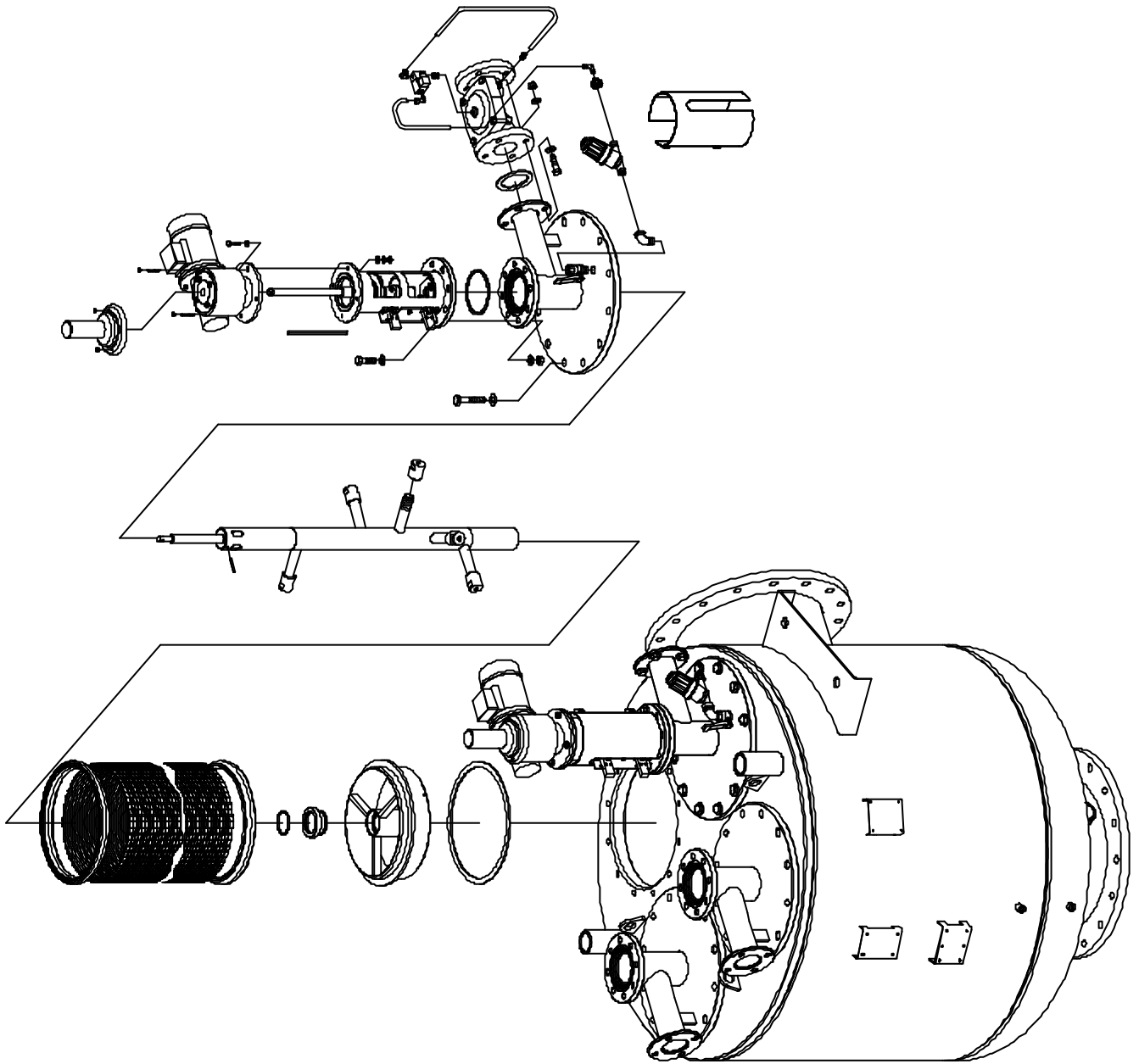

# PARTS DRAWING Section 1

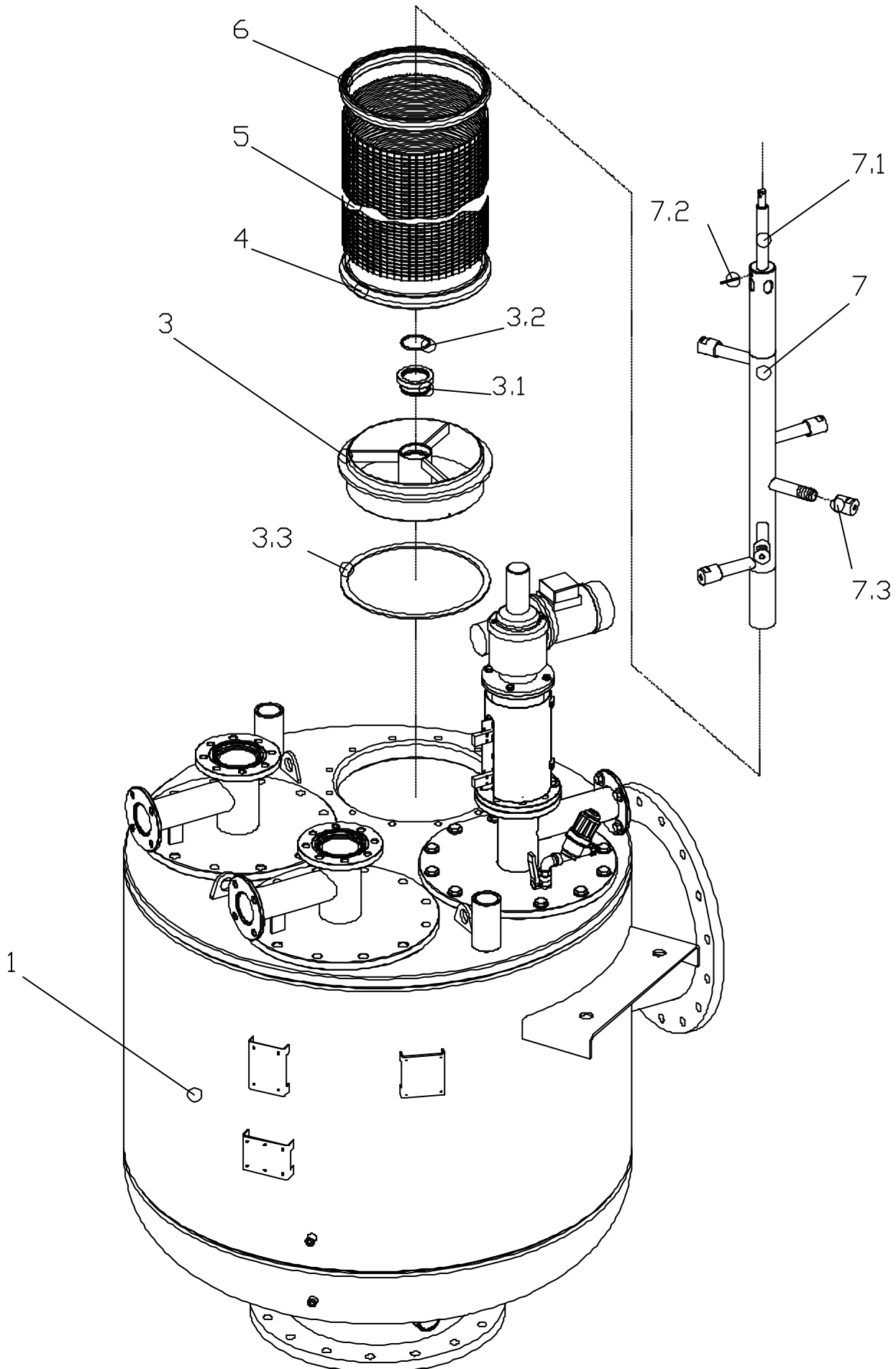

**PARTS DRAWING** Section 2

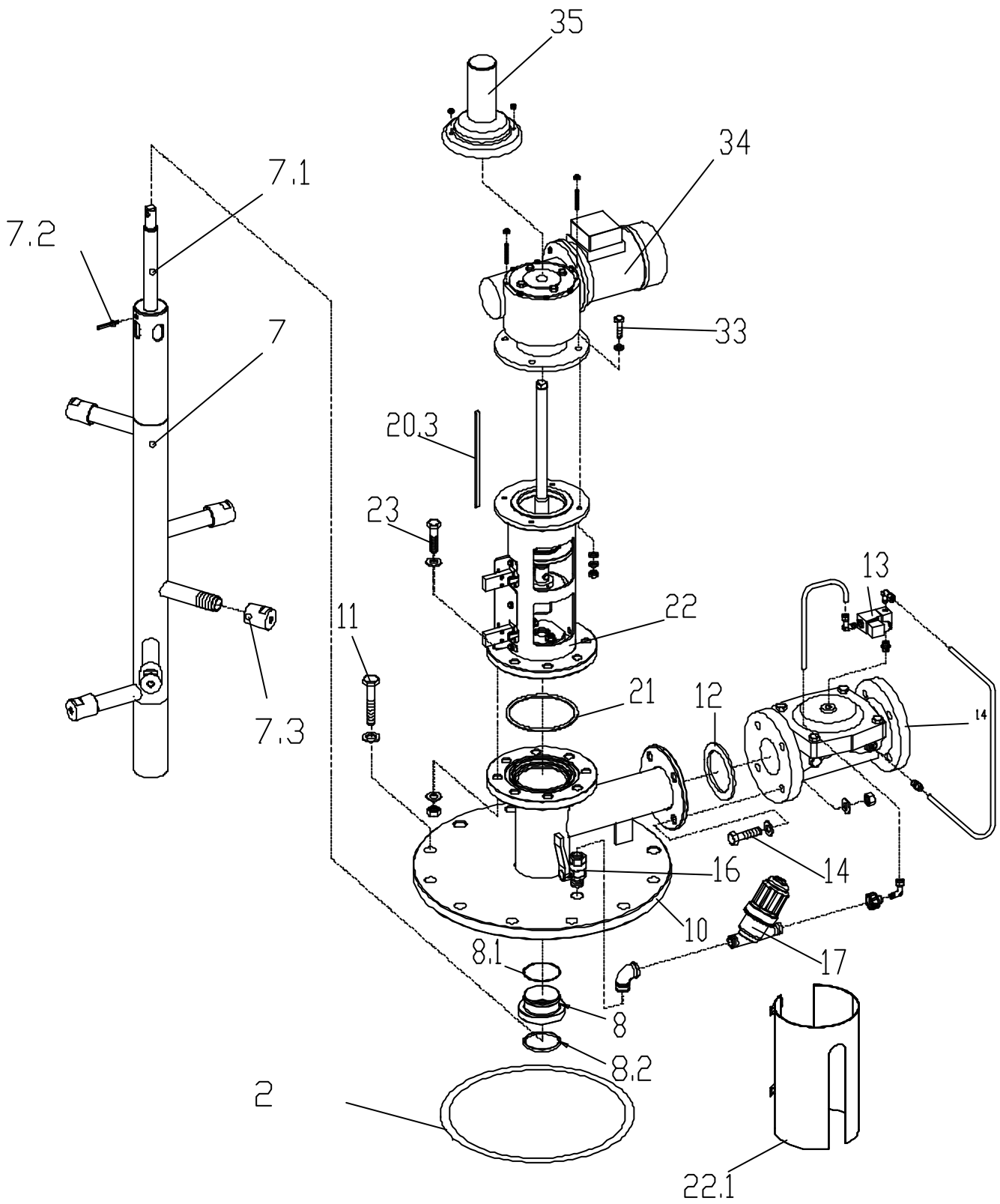

# PARTS DRAWING Section 3

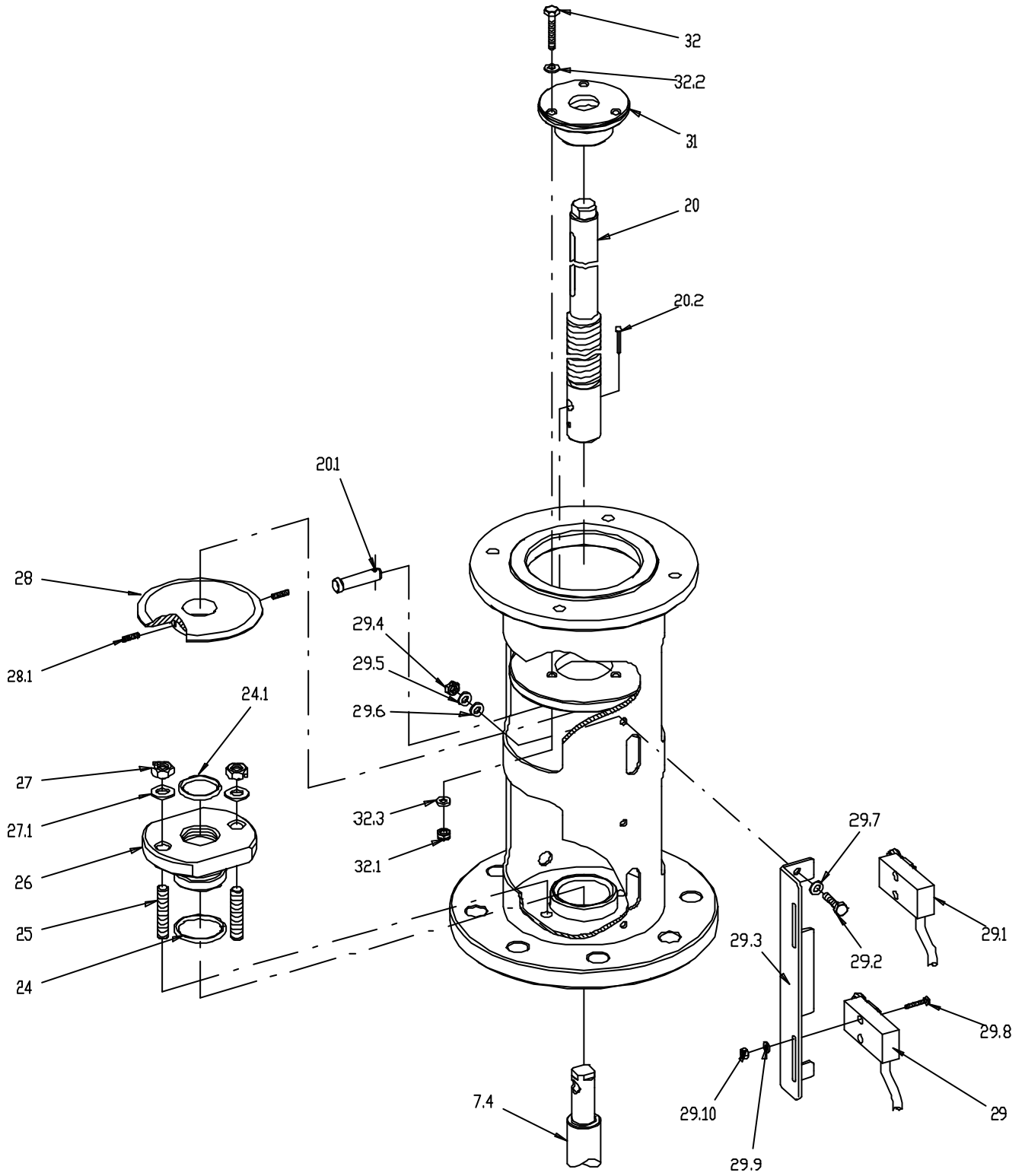

**PARTS DRAWING** Section 4

